

MULTIPLEX COMMUNICATION SYSTEM

PRECAUTION

1. DISCONNECT AND RECONNECT CABLE OF NEGATIVE BATTERY TERMINAL

NOTICE:

When disconnecting the cable from the negative (-) battery terminal, initialize the following systems after the cable is reconnected.

System Name	See procedure
METER / GAUGE SYSTEM	See page ME-10

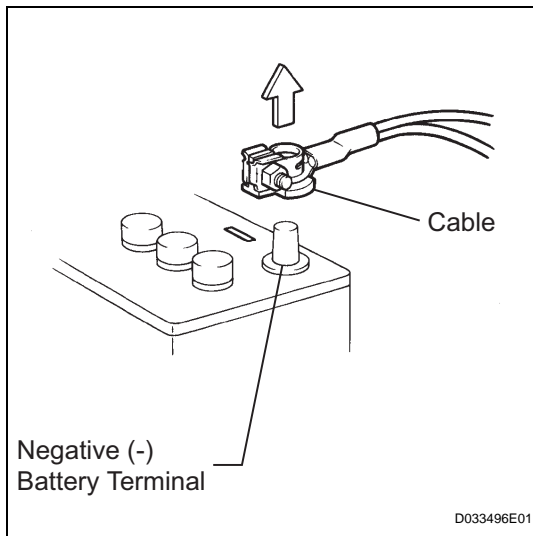

- (a) Before performing electronic work, disconnect the cable from the negative (-) battery terminal in order to prevent it from shorting and burning out.
- (b) Before disconnecting and reconnecting the battery cable, turn the ignition switch OFF and the headlight dimmer switch OFF. Then loosen the terminal nut completely. Do not damage the cable or terminal.
- (c) When the battery cable is disconnected, the clock and radio settings and stored DTCs are erased. Therefore, before disconnecting the battery cable, make a notes of them.

PARTS LOCATION

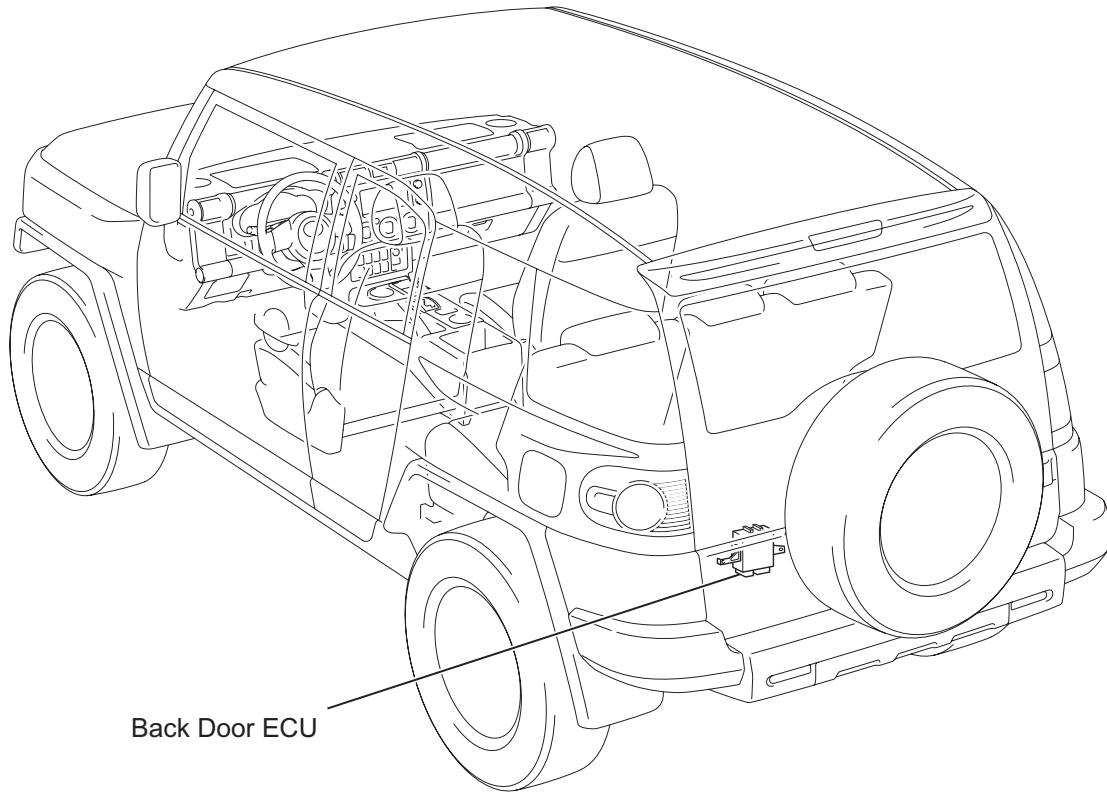

Back Door ECU

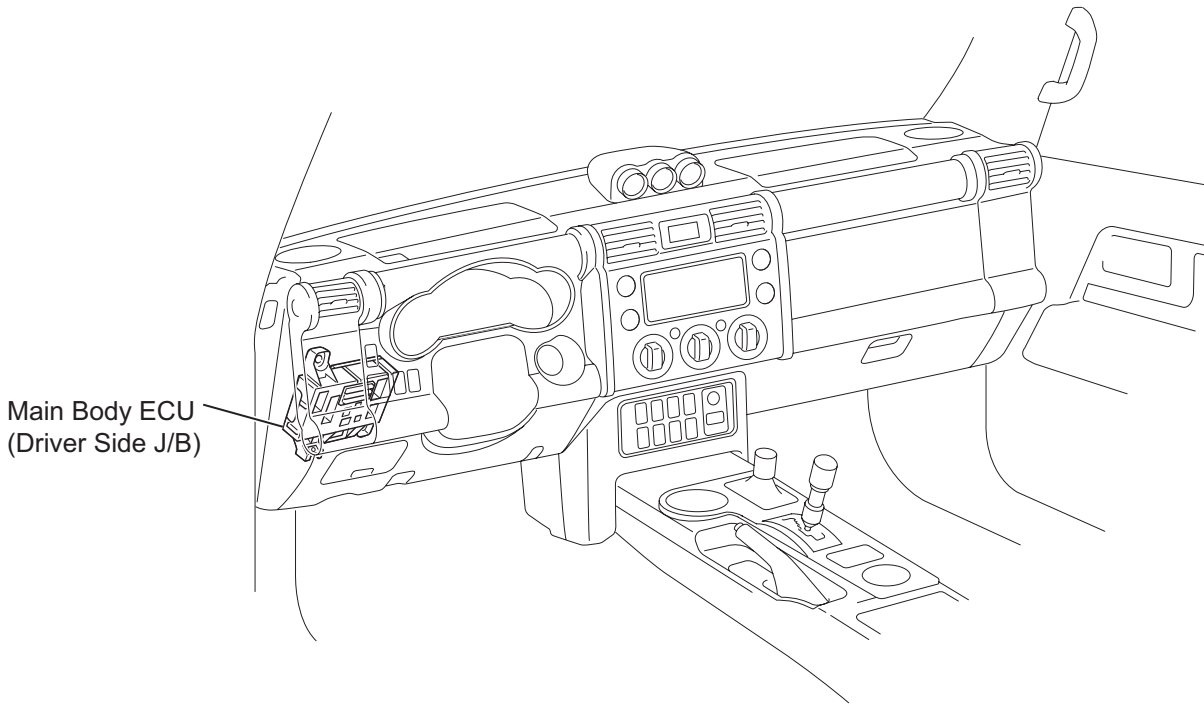

Main Body ECU
(Driver Side J/B)